

ArtCart



ArtCart Tool Kit + Application Form

Established in 2018, the ArtCart is owned and managed by Maroondah City Council. ArtCart is an innovative, mobile display space which encourages local artists and the community to participate in Maroondah's arts and cultural scene in surprising ways in public spaces.

ArtCart is part of the City of Maroondah's network of arts sites and facilities within the City of Maroondah and enables the celebration and promotion of arts and culture in an ever changing and dynamic fashion. Whilst primarily based at Maroondah Federation Estate, part of the Ringwood arts precinct, ArtCart is able to be borrowed and transported to sites throughout Maroondah. ArtCart has the capacity to showcase contemporary and traditional arts and cultural product.

ArtCart is primarily parked in the foyer of Maroondah Federation Estate, 32 Greenwood Avenue, Ringwood which includes a café and an attractive outdoor setting.

Maroondah Federation Estate Hours

Monday to Friday 8:30am – 5.00pm

Sundays and Public Holidays closed except by prior arrangement

ArtCart Contact

Belinda Robertson, Arts & Cultural Development Officer

belinda.robertson@maroondah.vic.gov.au / 9298 4537

Care of ArtCart

Please note that whilst Maroondah Federation Estate is staffed there is no direct monitoring of the ArtCart. Council will not be held responsible for loss, theft or damage to the ArtCart or its contents during the user period whether at MFE or during transport and use at another location. The user will be responsible for ensuring appropriate care of the ArtCart and will be held liable for any damage or theft.

ArtCart Support Includes

Arts and Cultural Development staff will provide advice and support with usage, promotion, signage and some installation equipment for ArtCart.

Transport

When ArtCart is to be used offsite from Maroondah Federation Estate transport arrangements must be discussed and agreed to in writing with Arts and Cultural Development staff.

Fees

The ArtCart is **free** for use by approved artists, cultural and community organisations.

ArtCart Sales

Work may be offered for sale by users. All sales and enquiries must be handled directly by the user. All artwork sales made over the hire duration must be processed directly by the user. Council will not be involved in the negotiation of sale.

ArtCart Selection Process

ArtCart applications are welcome on an ongoing basis throughout the year from local artists and arts and cultural groups wishing to utilise this mobile display space to showcase and/or sell contemporary and traditional arts and cultural product.

Priority will be given to applications:

- with relevance and/or connection to the local community
- which increase increase participation and profile of arts and culture across Maroondah; and
- encourage the community to participate in Maroondah's arts and cultural scene in surprising ways in public spaces.

Those interested in submitting an application are advised to discuss it first with the Arts and Cultural Development Officer. Please email Belinda Robertson on belinda.robertson@maroondah.vic.gov.au or call on 9298 4537.

Applications should be submitted no later than 3 weeks prior to proposed use.

How to Apply

Please complete the ArtCart Application Form in full. Copies can be downloaded at www.artsinmaroondah.com.au/ArtCart.aspx or via request to Belinda Robertson on the email below.

If you have any questions relating to any section of the Application Form or require assistance completing the form, please contact Belinda Robertson on belinda.robertson@maroondah.vic.gov.au or call on 9298 4537.

Submitting your application

All applications must be forwarded to the Arts & Cultural Development Officer:

Email: belinda.robertson@maroondah.vic.gov.au

Subject Line: ArtCart Application

Next Steps

- All applications will be acknowledged by email upon receipt
- Applicants will be notified of the outcome of their proposal by email

ArtCart images



To view a short film highlighting ArtCart's showcase potential please go to:

www.artsinmaroondah.com.au/ArtCart.aspx

ArtCart



ArtCart Application Form

Please type into this document and return to belinda.robertson@maroondah.vic.gov.au

Contact Details:

Name (primary contact):

Artist, arts + cultural or community group:

Address:

Email:

Telephone:

Website and/or FaceBook page:

Description of artist, arts + cultural or community group:

.....
.....
.....
.....
.....

Showcase Details

Title:

Dates: From To

Where: Maroondah Federation Estate Yes No

Other address:

Are there any associated activities, events or public programs? Yes / No

If yes, please describe.

.....
.....
.....
.....

Transport

If you intend to use ArtCart offsite, are you able to collect and return ArtCart to Maroondah Federation Estate? Yes / No

Please note: You must discuss your transport details with Arts & Cultural Development staff.

Images

Please attach high-res jpeg images of the type of content to be showcased.

Submit your application

All applications must be forwarded to the Arts & Cultural Development Officer:

Email: belinda.robertson@maroondah.vic.gov.au

Subject Line: ArtCart Application

MOBILE SHOP - SECTION 1

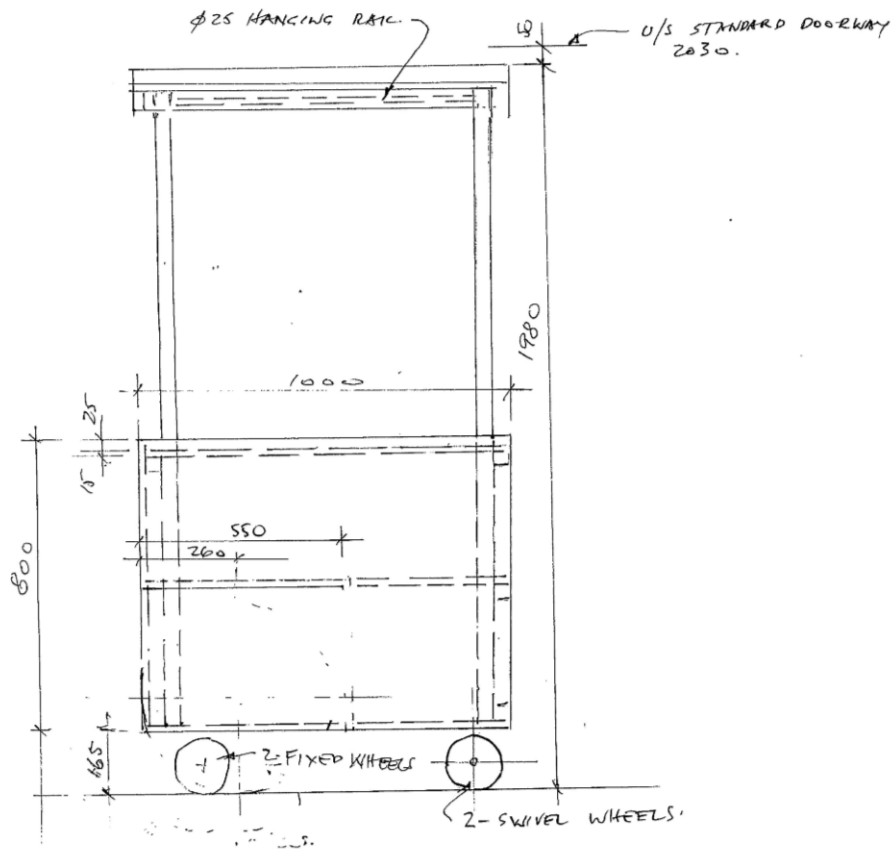

SIDE VIEW

SCALE 1:10

MOBILE SHOP - SECTION 2

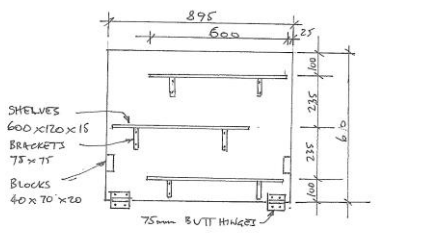

UNIT Z - REAR DISPLAY BOARD - 15mm PLY.

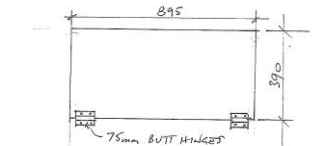

UNIT Z - FRONT FOLD DOWN COVER

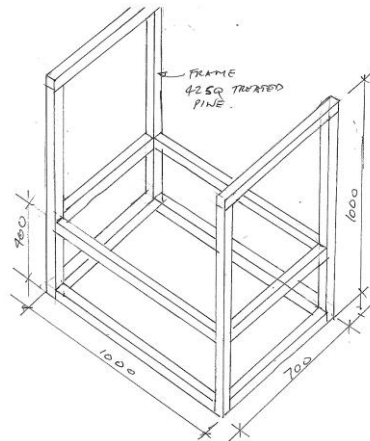

MOBILE SHOP
SECTION 2
FRAME

SCALE 1:10

SCALE 1:10

Drawings: Ted Wheelen - Croydon Mens Shed